

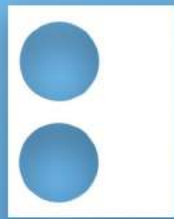

# Complete Hydronic Packages

# OVERVIEW



HEAT/COOL

+



STORE

+

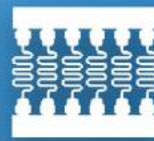

DISTRIBUTE

## HYDRONIC PACKAGES OVERVIEW

### TABLE OF CONTENTS

- Introduction ..... 1-2**
  - Simplifying Hydronics..... 1
  - Understanding Arctic Packages..... 2
- Engine Packages..... 3-7**
  - PKG-E-HC..... 4
  - PKG-E-HW..... 5
  - PKG-E-HCW..... 6
  - PKG-E-HCS..... 7
- Distribution Packages..... 8-12**
  - PKG-D-IF..... 9
  - PKG-D-FC..... 10
  - PKG-D-LV..... 11
  - PKG-D-HV..... 12
- Control Options..... 13-14**
- Complete Packages..... 15-18**
  - Standard Designs..... 16
  - Common Designs..... 17
  - Commercial..... 18
- Package Components..... 19-25**
  - EVI Heat Pump..... 20
  - Buffer Tanks..... 21
    - Standard..... 22
  - Radiant Floor ..... 23
  - Pumps and Valves..... 24
  - Controllers..... 25
- Ordering and Delivery info..... 26**
- Frequently Asked Questions..... 27-29**







## SIMPLIFYING MODERN HYDRONICS.

Arctic is a North American team of professionals specializing in modern hydronics. We stand out in this industry because we make our products and knowledge accessible to homeowners, building owners, and tradesmen. We believe this leads to a better customer experience.

This document was created to answer a simple question: What do I need to install an Arctic heat pump for my project?

By using our Arctic EVI heat pump as the primary heating/cooling source for your project, you will be running what is referred to as a low supply temperature hydronic system. This style of hydronics requires special components and design considerations to ensure reliability, performance, and efficiency.

For those who want to utilize our industry leading air to water heat pumps but are having troubles understanding what components/design their unique project requires in order to do so, we have created Arctic Packages, and put together this corresponding document to help you understand them.

# COMPLETE HYDRONIC SYSTEM

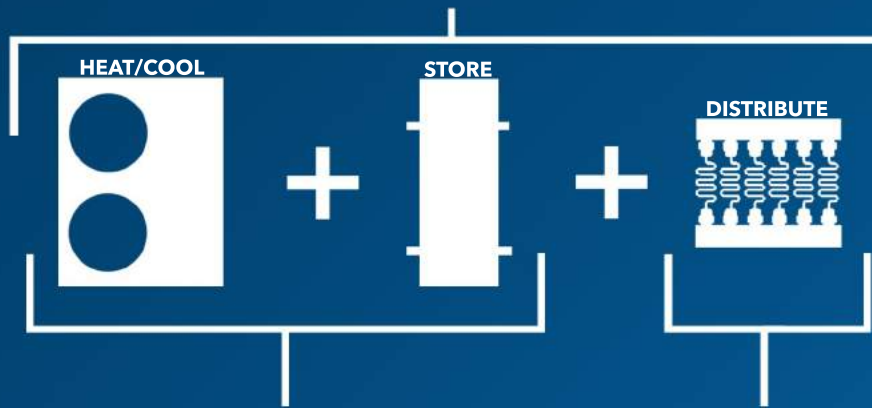

ARCTIC ENGINE PACKAGE + ARCTIC DISTRIBUTION PACKAGE

## CHOOSE ONE

1. **PKG-E-HC** SINGLE TANK HEATING & COOLING
2. **PKG-E-HW** SINGLE TANK HEATING + DOMESTIC HOT WATER
3. **PKG-E-HCW** DUAL TANK HEATING & COOLING + DHW
4. **PKG-E-HCS** SINGLE TANK HEATING & COOLING + SOLAR THERMAL

**OPTIONAL:** ENGINE CONTROLLER UPGRADE

## CHOOSE ANY COMBINATION

- + 1. **PKG-D-IF** HYDRONIC RADIANT FLOOR DISTRIBUTION
- + 2. **PKG-D-FC** HYDRONIC FAN COIL DISTRIBUTION
- + 3. **PKG-D-LV** LOW VELOCITY HYDRONIC FORCED AIR DISTRIBUTION
- + 4. **PKG-D-HV** HI-VELOCITY HYDRONIC FORCED AIR DISTRIBUTION

**Or** Use your existing distribution system

**OPTIONAL:** DISTRIBUTION ZONE CONTROLLER UPGRADE

## UNDERSTANDING ARCTIC PACKAGES

Arctic packages are comprised of specialized hydronic components that are engineered/installed in order to reliably provide a function within your hydronic system.

Every customer brings a unique project, and as such the component specs in your Arctic Package will be fully custom and unique to what your project requires.

Every Hydronic system can be split into two parts. As such, Arctic offers two package categories:

### Production and Storage - Arctic Engine Packages

Arctic Engine packages contain all the hydronic components you will require in order to produce and store hot and cold fluid. You can retrofit these packages into existing hydronic distribution, or purchase Arctic distribution packages to distribute the energy these packages create.

### Distribution - Arctic Distribution Packages

Arctic Distribution packages contain all the hydronic components you will require in order to distribute hot and cold hydronic fluid throughout building. They are modular packages, meaning multiple distribution packages can be added to a single Arctic Engine.

# ARCTIC ENGINE PACKAGES

HEAT/COOL



STORE



PKG-E-HC



PKG-E-HCS



PKG-E-HW



PKG-E-HCW



## MANUAL J STUDY

Although an Arctic representative can estimate the Arctic Engine specifications required for your project based on general information like square footage and location, a manual J calculation is always recommended before purchasing. This report will calculate the heating and cooling demand your building has at your outdoor design temperatures. Arctic can use this report to accurately size all components, ensuring reliability and efficiency. Arctic provides manual J calculations, and your design charge will be rebated back if you purchase Arctic Engine.





## PKG-E-HC STANDARD ARCTIC ENGINE PACKAGE SINGLE TANK - HEATING + COOLING

**FUNCTION:** To produce hot and cold hydronic fluid with Arctic EVI heat pump, and use that energy to keep an Arctic Hybrid buffer tank at desired set hot/cold temperature.

**Why Choose?:** Choose this Engine package when you require both heating and cooling functionality. PKG-E-HC is our standard Arctic Engine package, and our most affordable Engine configuration.

### DESIGN CONFIGURATION



#### Standard Components:

1. Arctic EVI heat pump - sized to Manual J
2. Stock EVI controller - Upgrade to HBX control option available
3. Arctic snow stand - Required in climates hitting sub-freezing temperatures (substitute for alternative stand available)
4. Grundfos 240V circulation pump - One per EVI heat pump
5. Grundfos isolation valves - One set per circulation pump
6. Arctic Hybrid tank - Sized to EVI heat pump
7. T2 Ultra electric boiler - Sized to Manual J  
(option to substitute for existing boiler or carbon source boiler)
8. Grundfos 120V circulation pump - Supplied with T2 boiler



## PKG-E-HW UPGRADED ARCTIC ENGINE PACKAGE SINGLE TANK - HEATING + DOMESTIC HOT WATER

**FUNCTION:** To produce hot hydronic fluid with Arctic EVI heat pump, and use that energy to keep a Thermo2000 Alt Source tank at desired set temperature. Alt Source has built in electric backup boiler and copper DHW heat exchanger.

**Why Choose?:** Choose this Engine package when you do not require hydronic cooling. PKG-E-HW allows customer to get great efficiency pre- heating DHW when space heating no longer required, reducing system payback.

### DESIGN CONFIGURATION

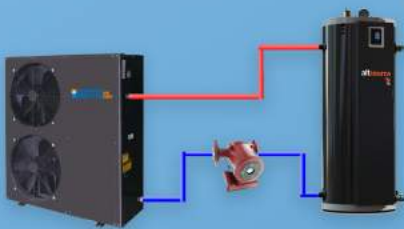

#### Standard Components:

1. Arctic EVI heat pump - sized to Manual J
2. Stock EVI controller - Upgrade to HBX control option available
3. Arctic snow stand - Required in climates hitting sub-freezing temperatures (substitute for alternative stand available)
4. Grundfos 240V circulation pump - One per EVI heat pump
5. Grundfos Isolation valves - One set per circulation pump
6. Thermo2000 Alt Source Tank - Sized to EVI heat pump and manual J

\*Standard domestic hot water tank or tankless heater required to be paired with Alt Source DHW coil\*





# PKG-E-HCW

## UPGRADED ARCTIC ENGINE PACKAGE

### DUAL TANK - HEATING and COOLING + DOMESTIC HOT WATER

**FUNCTION:** To produce hot and cold hydronic fluid with Arctic EVI heat pump, and use that fluid to keep an Arctic Hybrid buffer tank, and a T2000 Alt Source tank at desired set temperatures. In summer, EVI heat pump will keep Hybrid tank cold for space cooling, and Thermo2000 tank hot for DHW heating.

**Why Choose?:** Choose this Engine package when you require full heat pump functionality. PKG-E-HCW allows customer to utilize all functions of heat pump, but sacrifices on payback for those features.

#### Standard Components:

1. Arctic EVI heat pump - sized to Manual J
2. Stock EVI controller - Upgrade to HBX control option available
3. Arctic snow stand - Required in climates hitting sub-freezing temperatures (substitute for alternative stand available)
4. Grundfos 240V circulation pump - One per EVI heat pump
5. Grundfos isolation valves - One set per circulation pump
6. Thermo2000 Alt Source tank - Sized to EVI heat pump and manual J
7. Arctic Hybrid tank - Sized to EVI heat pump
8. Belimo 240V 3-way valve assembly - Supplied with dual tanks

#### DESIGN CONFIGURATION

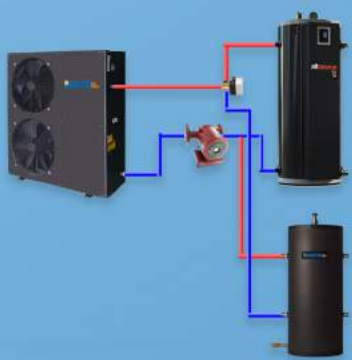

\* Standard domestic hot water tank or tankless heater required to be paired with Alt Source DHW coil\*





# PKG-E-HCS

## UPGRADED ARCTIC ENGINE PACKAGE

### HYBRID SYSTEM - HEATING and COOLING + SOLAR DOMESTIC HOT WATER

**FUNCTION:** To produce hot and cold hydronic fluid with Arctic EVI heat pump, and use that fluid to keep an Arctic Hybrid buffer tank at desired set temperatures. An SWH-2 solar thermal package is paired with Arctic Engine, providing DHW completely powered by sun, and allowing for solar thermal tank dumping into hydronic space heating system.

**Why Choose?:** Choose this Engine package when you require maximum electrical efficiency. PKG-E-HCS allows customer to utilize both Arctic EVI heat pump, and solar thermal system, to their maximum efficiencies.

#### Standard Components:

1. Arctic EVI heat pump - sized to Manual J
2. Stock EVI controller - Upgrade to HBX control option available
3. Arctic snow stand - Required in climates hitting sub-freezing temperatures (substitute for alternative stand available)
4. Grundfos 240V circulation pump - One per EVI heat pump
5. Grundfos isolation valves - One set per circulation pump
6. T2 Ultra electric boiler - Sized to Manual J  
(option to substitute for existing boiler or carbon source boiler)
7. Arctic Hybrid tank - Sized to EVI heat pump
8. Grundfos 120V circulation pump - Supplied with T2 boiler
9. Belimo 240V 3-way valve assembly - Supplied with dual tanks
10. Resol MX controller - Used to control EVI and solar interaction
11. NLSS SWH-2 solar thermal package - Supplied with 120G tank

### DESIGN CONFIGURATION

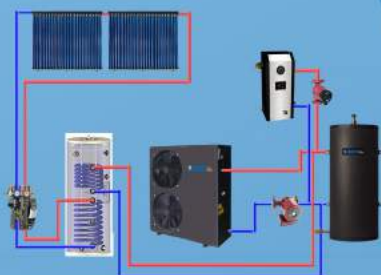

# ARCTIC DISTRIBUTION PACKAGES

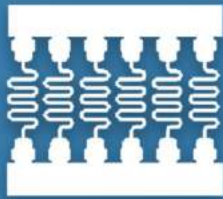

IN-FLOOR



FORCED AIR



FAN COILS

PKG-D-IF



PKG-D-FC



PKG-D-LV



PKG-D-HV



**MODULAR:** Arctic distribution packages can be combined together, and paired to same Arctic Engine.

## SIZING AND DESIGN

Each distribution package is designed and sized using a unique process specialized to the technology. In all cases, a manual J design is recommended before purchasing. Specialized Arctic design services are required in order to purchase D-IF and D-HV distribution packages.





## PKG-D-IF CUSTOM HYDRONIC RADIANT FLOOR DISTRIBUTION PACKAGE

**Function:** Provides radiant floor heating and cooling to building. Radiant floor heating, especially when installed into a concrete slab, is known for being the most comfortable and efficient form of heating available. Arctic also specializes in radiant floor cooling, and all D-IF packages can be configured for reliable summer cooling in most of North America. Each D-IF package is fully customized to the specifications of unique project.

**Features:** Custom zoning, multi-zone manifold systems, in-floor cooling, optional remote control and monitoring, PE-RT pipe, UL/CSA certified designs.

**Sizing/Design:** Purchase Arctic radiant floor + manual J design service. Due to project variances, an Arctic manufacturer's representative is not able to provide quote estimates for D-IF package.

**Choose when?:** Radiant floor heating is a terrific option for customers who desire efficiency. In floor heating is very comfortable, it does not produce any noise and heats from floor up. Radiant cooling is a terrific option for customers who are investing in radiant floor heating, and don't require direct air cooling. The limitation of radiant floor heating can be response time, although advance controllers can mitigate this. The limitation of radiant floor cooling can be humidity control, although external de-humidification methods and the provided ECO-0550 controller and dew point sensor will prevent any issues.

### STANDARD COMPONENTS

1. IVAR pex manifolds - Sized to project
2. Vipert PE-RT piping - Sized to project
3. Zone relay system - Either Caleffi ZSR/ZVR or HBX Zon system
4. IVAR 24V manifold actuators - For multi-zone manifold applications
5. Resol dew point sensor - Supplied with radiant floor cooling equipped D-IF packages
6. Grundfos 15-55 120V circulation pump - Standard head pressure circulation pump
7. Grundfos 26-99 120V circulation pump - High head pressure circulation pump
8. Grundfos isolation valves - One set per circulation pump



## PKG-D-FC CUSTOM HYDRONIC FAN COIL DISTRIBUTION PACKAGE

**Function:** Provide easily zoned direct to air hydronic heating and cooling. Typically fan coils are an added distribution package paired with our radiant floor D-IF package. They provide very effective heating and cooling to individual rooms/zones.

**Features:** Heating and cooling, built in thermostats and control, built in condensation drain assembly, 3 fan speeds + auto, multi-zone manifold design options.

**Sizing/Design:** A room to room manual J report is recommended to accurately size fan coils per room/zone demand loss. An Arctic manufacturer's representative can provide quote estimate for FC distribution package using building design plan.

**Choose when?:** Our fan coil package is a terrific option for smaller homes, or homes with very open design plans. Fan coils also offer unique zoning abilities, especially in homes with radiant floor distribution. For little investment, a few fan coils can be added to specific areas in home and provide high performance heating and cooling in those areas. Fan coils are often paired with radiant floor cooling in specific zones that require colder room temperatures. The limitation of fan coils is that they provide little economy of scale. If lots of fan coils would be required to heat & cool a larger home, we tend to recommend client investigate forced air or radiant floor distribution for better economy of scale.

### STANDARD COMPONENTS

1. Arctic fan coils - Sized to project
2. IVAR pex manifolds - For multi-fan coil zoning applications
4. IVAR 24V manifold actuators - Supplied with IVAR manifold
3. Zone relay system - Either Caleffi ZSR/ZVR or HBX Zon system
6. Grundfos 15-55 120V circulation pump - Standard head pressure circulation pump
7. Grundfos 26-99 120V circulation pump - High head pressure circulation pump
8. Grundfos isolation valves - One set per circulation pump





## PKG-D-LV LOW VELOCITY HYDRONIC FORCED AIR DISTRIBUTION PACKAGE

**Function:** Provide heating and cooling using standard HVAC ducting. Our D-LV distribution package is terrific for retrofitting an Arctic engine into an existing conventional ducting system. With a variable speed fan motor, you can set air speed to desire.

**Features:** Variable speed fan motor, ultra-quiet operation, low temperature rated hydronic coil, small frame design for easy installation.

**Sizing/Design:** A manual J report is recommended to accurately size air handler. An Arctic manufacturer's representative can provide quote estimate for D-LV distribution package using building design plan.

**Choose when?:** Our low velocity package is a terrific option for furnace retrofit, or when a standard duct system is desired on a new build. D-LV distribution packages are very affordable, allowing for great economy of scales when client requires complete building heating and cooling. The limitation of this package is its inability to be zoned. D-LV packages are also not as efficient to operate as other distribution packages due to requiring higher supply temperature from Arctic Engine to operate air handler.

### STANDARD COMPONENTS

1. Arctic LV-Z air handler - Sized to project
3. Zone Relay system - Either Caleffi ZSR/ZVR or HBX Zon system
6. Grundfos 15-55 120V circulation pump - Standard head pressure circulation pump
8. Grundfos Isolation valves - One set per circulation pump



## PKG-D-HV CUSTOM HI-VELOCITY HYDRONIC FORCED AIR DISTRIBUTION PACKAGE

**Function:** Provide heating and cooling using custom Hi-Velocity ducting. Extremely efficient and effective, Hi-Velocity offers many industry leading forced air features such as zoning, insulated ducting, and variable speed fan motors.

**Features:** Variable speed fan motor, ultra-quiet operation, low temperature rated hydronic coil, optional 4-zone valve, specialized Hi-Velocity insulated branch ducting - 2" I.D, optional upgraded vent finishes.

**Sizing/Design:** A specialized Hi-Velocity design/quote service is required before purchasing. Due to project variances, an Arctic manufacturer's representative is not able to provide quote estimates for HV package.

**Choose when?:** Our Hi-velocity package is a terrific option for new builds, giving building owners industry leading performance in an easily installable package. Hi-velocity is also a terrific option for cast iron radiator retrofitting, allowing a new forced air system to be installed in its place. This distribution package can provide very cold air and respond to temperature changes quickly. The limitation of this package is efficiency, requiring a higher supply temperature to operate compared to radiant floor heating.

### STANDARD COMPONENTS

1. Arctic HE-Z air handler and custom ducting system - Sized to project
3. Zone Relay system - Either Caleffi ZSR/ZVR or HBX Zon system
6. Grundfos 15-55 120V circulation pump - Standard head pressure circulation pump
8. Grundfos isolation valves - One set per circulation pump



# ARCTIC CONTROLLERS

---



---

**Each Arctic package comes standard with a basic control system. We offer upgraded control options for when you require advanced functionality from your package.**

**Arctic also offers a complete hydronic control system, with remote control and monitoring functionality in a centralized platform.**



## COMPLETE HYDRONIC CONTROL SYSTEM



### HBX CONTROL SYSTEM

**Function:** Provides a central online monitoring and remote-control platform for Arctic Engine package + Arctic Distribution package (not including PKH-D-FC) or existing distribution system. This is a complete hydronic control system.

**Features:** Upgraded ECO-0550 Engine controller, Upgraded ZON-0550 Distribution zone system., Optional snow melt control, touch screen thermostats, complete remote control and monitoring via smartphone device. Gain peak efficiency, performance, and accessibility from your hydronic system.

**Choose When?:** You desire a premium, centralized, and simple control system for your entire hydronic system. One that enables advanced functionality and efficiency from your hydronic equipment.

## ARCTIC ENGINE CONTROL OPTIONS

### UPGRADED HBX ECO-0550



**Function:** Enable advanced features from Arctic Engine.

**Features:** WIFI and online monitoring and control platform, in floor cooling control, outdoor reset, priority selection, relay zone control, multiple heat pump staging.

**Choose When?:** You desire a simple and functional cloud-based monitoring and control platform, want to achieve maximum functionality with Arctic engine, or have multiple heat pumps.



### STANDARD EVI CONTROLLER

**Function:** Provide basic control for Arctic Engine.

**Features:** WIFI connectivity, priority selection, backup boiler control, heating and cooling.

**Choose When?:** You require basic control functionality from Arctic Engine package. Provided as standard control option for all Arctic Engine packages.



### SPECIALIZED RESOL MX

**Function:** Enable multi-temperature and solar thermal applications from Arctic Engine.

**Features:** In floor cooling control, solar thermal control, optional outdoor reset, relay zone control, multi temperature application control.

**Choose When?:** for multi-distribution cooling applications that include radiant floor. This controller is also supplied with HCS Engine.

## ARCTIC DISTRIBUTION CONTROL OPTIONS

### UPGRADED ZON-0550 SYSTEM



**Function:** To provide remote control and monitoring functionality to Arctic distribution package.

**Features:** Multi-zone control, 120V and 24V relay control, THM-0500 touch screen thermostats, ThermoLinx WIFI control and monitoring platform.

**Choose When?:** Distribution monitoring or remote control for Arctic distribution is desired. Not available for PKG-D-FC package.



### STANDARD CALEFFI Zone Relay System

**Function:** Provide basic zone control using standard thermostats.

**Features:** Multi-zone control, 120V and 24V relay control.

**Choose When?:** Basic zone control for Arctic distribution desired.





# COMPLETE HYDRONIC PACKAGES



## UNIQUE PROJECTS. CUSTOM SOLUTIONS.

Once you have determined the Engine and Distribution packages you would like to select for your project, let us at Arctic design a custom package with all the components you will require for the reliable operation of your hydronic system.

# COMPLETE HYDRONIC PACKAGES: STANDARD

## H-H

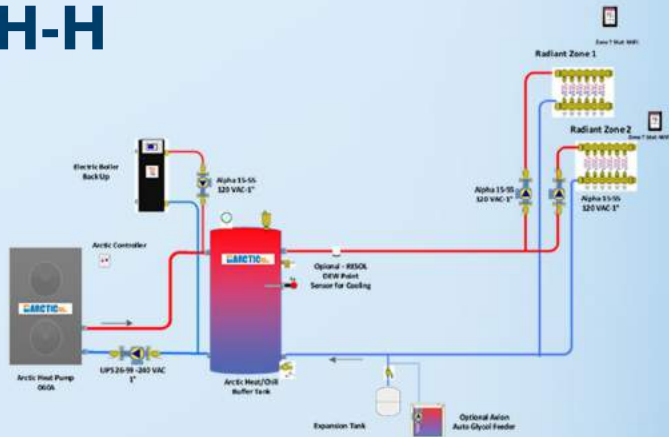

HEATING AND COOLING



## A-A

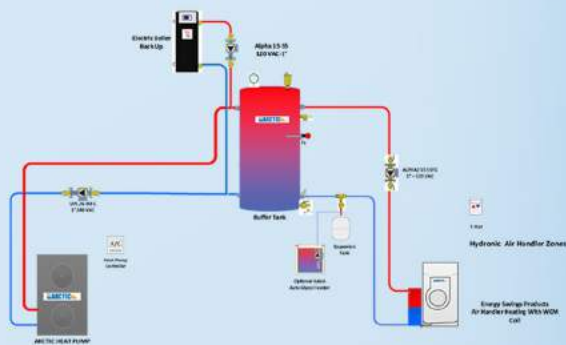

HEATING AND COOLING



## F-F

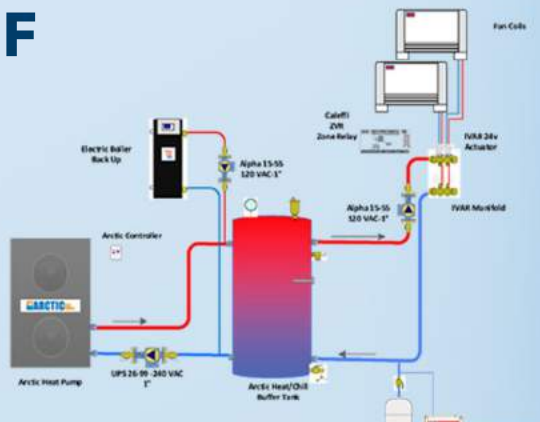

HEATING AND COOLING





# COMPLETE HYDRONIC PACKAGES: COMMON DESIGNS

## HF-W1

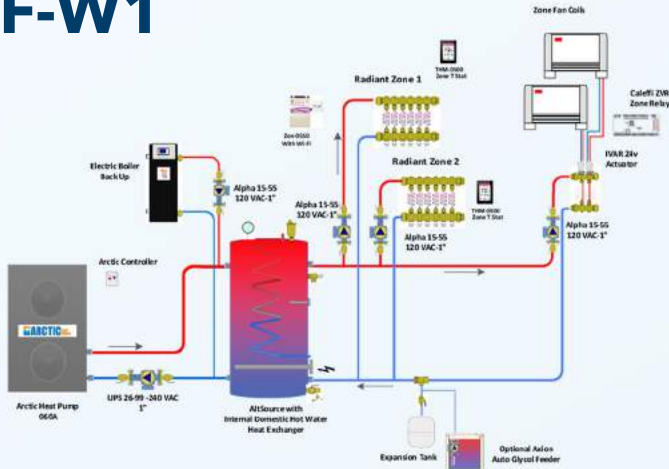

## HA

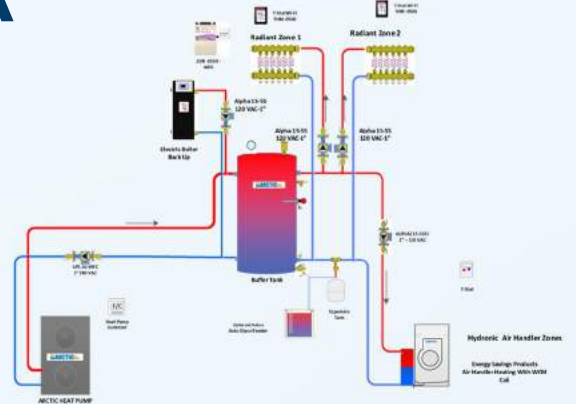

## H-W1

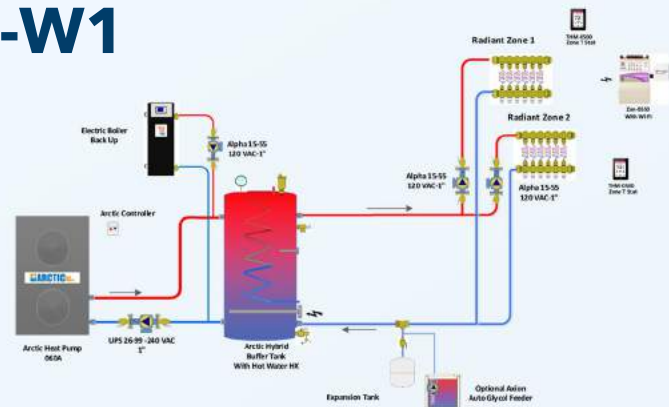

## FA-FA-W2

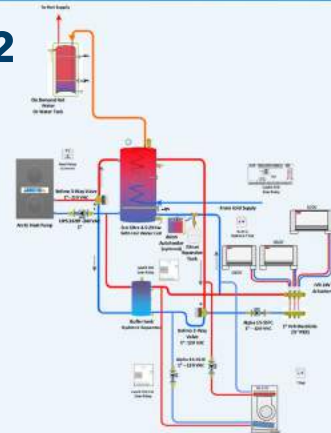

## HF

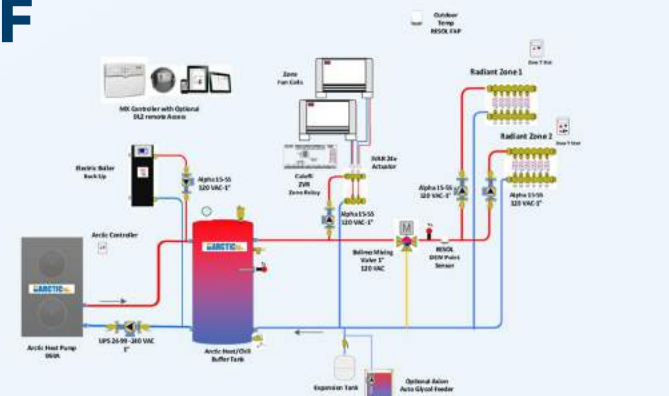

## HA-HA-W2

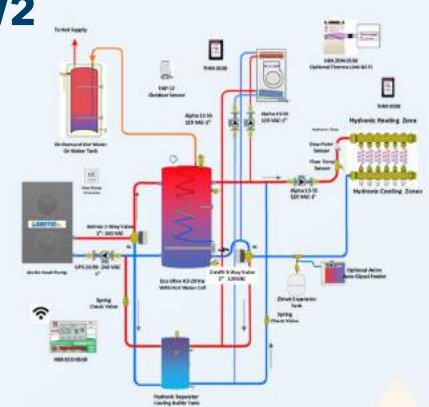

# COMPLETE HYDRONIC PACKAGES: COMMERCIAL - SINGLE PHASE

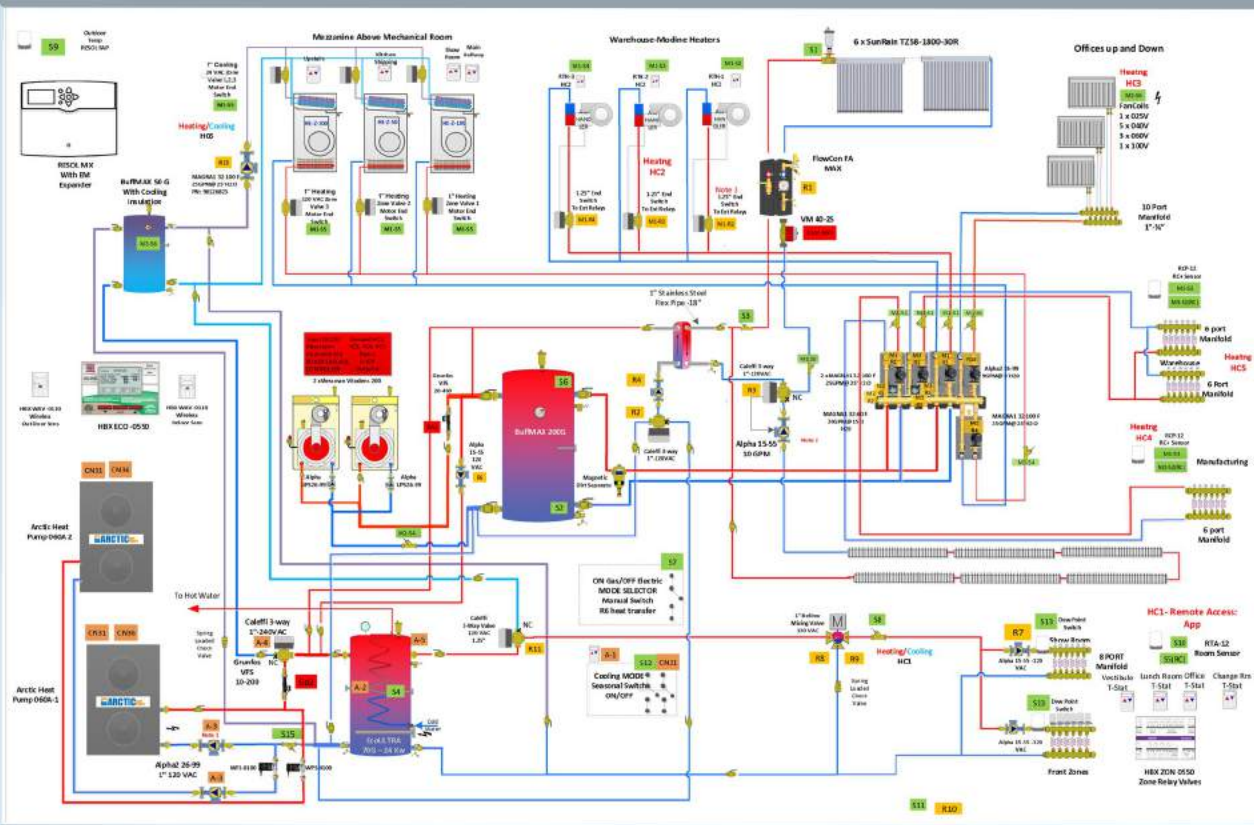



# PACKAGE COMPONENTS

---







# PACKAGE COMPONENTS: HYDRONIC BUFFER TANKS



## ARCTIC HYBRID BUFFER TANK COMPOSITE HOT/COLD TANK

The Arctic Hybrid tank is the only pressurized composite buffer tank on the market! Lightweight, efficient, and won't rust! It also greatly improves system efficiency by reducing heat pump short cycling during low load periods, making it extremely cost effective. It is one of few tanks that can be horizontally mounted. It comes stock with cold water insulation, meaning condensation cannot form on exterior when holding cold water.

### FEATURES:

- Composite materials - Lightweight and won't rust
- 43% higher R value than next leading comparable volume buffer tank
- 41% less heat loss than next leading comparable volume buffer tank
- Threaded stainless steel water connections
- Strand fiberglass inner tank is strong, light, and won't rust out
- Stainless steel reinforced thermal well port
- Injected closed cell foam minimizes temperature loss and maximizes efficiency
- Durable matte black plastic outer jacket
- 5-year warranty

**SIZE OPTIONS:** (Gallons / Diameter" x Height")

**22/21x31 • 40/21x56 • 55/21x73 • 80/29x54 • 120/29x74**

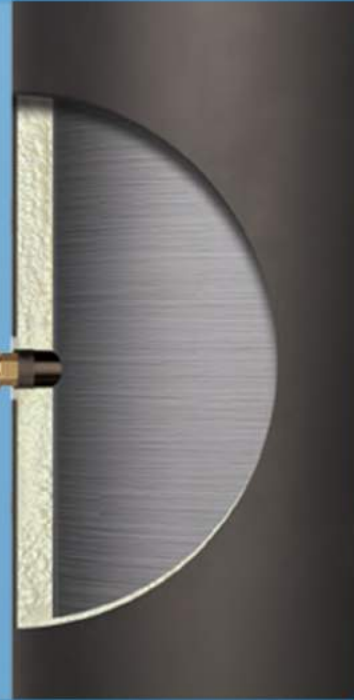

## THERMO2000 ALT SOURCE TANK BUILT IN ELECTRIC BOILER/HOT WATER HX TANK

Alt Source is the only electric high-volume boiler on the market, and is the perfect complement to the Arctic EVI heat pump. This combination boiler-storage tank is designed for residential use and is practically maintenance-free. It comes equipped with built in copper heat exchange coil to use heat pump for heating domestic hot water, and has a range of built-in electric boiler size options.

### FEATURES:

- ULTRASMART™ Controller
- BUILT IN 4.5KW-29KW multi-stage electric boilers
- Temperature and pressure indicator
- Copper heat exchanger
- 15-Year tank and coil warranty
- 2-year electrical and mechanical warranty

**SIZE OPTIONS:** (Gallons / Diameter" x Height")

**48/22x56.5 • 71/24x66.25**

**ELECTRIC BOILER OPTIONS:** (KWH / STAGES / AMPS)

**4.5/1/19    7.5/2/31    9/2/38    12/2/50    15/4/63**  
**18/4/75    20/4/83    24/4/100    27/6/113    29/6/120**



# PACKAGE COMPONENTS: STANDARD



## ARCTIC SNOW STAND

1/4" steel angle iron ground stand for Arctic heat pumps. Pre-drilled mounting holes. Powder coated white.

**Dimensions: (L" x W" x H")**  
50.5" x 23" x 26"



## T2000 BTH & MINI ULTRA BOILERS

BTH and Mini Ultra electrical boilers are compact and highly performant. They pair well as backup boiler for Arctic Engine packages.

**CAPACITY RANGE:**  
3 KWH to 36 KWH

**DIMENSIONS: (L" x W" x H")**  
BTH: 11x11.75x21.5 MINI: 9x8.75x21.5



## ARCTIC FAN COILS

Arctic Fan coils are a versatile and efficient method of hydronic heating and cooling.

### FEATURES:

- Easy Zoning ability
- Precision temperature control
- Ultra thin (5")
- Flexible mounting styles
- 30% more efficient than standard radiators
- Brushless DC fan motors - efficient and quiet

### MODEL/BTU HEATING OUTPUT

MODEL	BTU HEATING OUTPUT
PFP-025V	3,600
PFP-040V	6,900
PFP-060V	9,200
PFP-080V	11,800
PFP-100V	14,300



## ARCTIC AIR HANDLERS

Arctic air handlers are a cost effective method of producing high performance hydronic heating and cooling.

### FEATURES:

- Variable Speed fan
- High static air flow
- High build quality
- Heating and cooling
- Energy efficient
- Compact

### MODEL/DIMENSIONS (L" x W" x H")

MODEL	DIMENSIONS (L" x W" x H")
HE-Z-50	32.5x14.5x18.25
LV-Z-1050/HE-Z-70	32.5x19.5x18.25
HE-Z-100	32.5x25.5x18.25
LV-Z-1750	38.5x26.75x24.25





# PACKAGE COMPONENTS:

## RADIANT FLOOR COMPONENTS



### VIPERT RADIANT TUBING

POLYETHYLENE-RAISED TEMPERATURE WITH OXY-BARRIER

#### FEATURES:

- Strength and Durability
- 100% recyclable
- Improved flexibility
- 25-year warranty
- Certified for F-1960 Cold Expansion

**COLOR:** Green

**DIAMETERS:** 3/8" - 1/2" - 3/4" - 5/8" - 1" - 2"



### IVAR MANIFOLDS

High-quality stainless-steel manifolds for hydronic heating and cooling.

#### FEATURES:

- AISI 304 high gauge stainless steel
- Large transit section for increased flow rate
- Lightweight and easy to install
- Compatible with both low and high temperatures
- Optimal mechanical resistance to corrosion

**MANIFOLD OPTIONS:** 2-13 ports



### IVAR 24V ZONE ACTUATOR

Used to perform multi-zoning function from single IVAR manifold for some radiant floor and fan coil applications.



### RESOL DEW POINT SWITCH

Used to perform condensation prevention for radiant floor cooling.

# PACKAGE COMPONENTS: CIRCULATION PUMPS/VALVES



## GRUNDFOS-UPS26-99 FC -240 VAC-

Standard Arctic heat pump circulation pump

### FEATURES:

- Built-in motor protection
- Whisper-quiet operation
- Built in Check Valve

### SPECIFICATIONS:

Voltage: 208-240V / 3-speed motor / Head Range: 0-29 ft;



## GRUNDFOS ALPHA2 15-55F -120 VAC-

Standard distribution circulation pump

### FEATURES:

- Large display - shows current energy consumption & estimated GPM
- Line chord option - 110-120 VAC
- Insulated pump jacket
- AutoAdapt flow range

### SPECIFICATIONS:

Voltage: 110-120V / Variable Speed / Head Range: 0-19 ft;



## GRUNDFOS ALPHA2 26-99FC -120 VAC-

High head pressure distribution circulation pump

### FEATURES:

- 8 intelligent control modes:
- High efficiency
- System and pump protection warning and alarm indicators
- LED light indicators

### SPECIFICATIONS:

Voltage: 110-120V / Variable speed / Head Range: 0-42 ft



## BELIMO MIXING VALVE -120 VAC-

Used for multi-temperature distribution applications. Paired with Resol MX controller. 3-way mixing valve.



## GRUNDFOS ISOLATION VALVE KIT

Dielectric isolation 1" NPT valve set for Grundfos ALPHA, UP, and UPS pumps

### FEATURES:

- Full port shut-off ball valve
- Reduces installation time
- Service pump without draining system
- Swivel flange allows optimum pump mounting position



## BELIMO 3-WAY VALVE -24V / 120V / 240V-

Used for multi-source buffer tank hydronic applications. Can be controlled using various Arctic control options.



# PACKAGE COMPONENTS: CONTROLLERS



## HBX ECO-0550

Enables advanced functionality from Arctic Engine. Built in cloud-based monitoring.

### FEATURES:

- Heating and cooling outdoor reset
- Stage up to 3 heat pumps - seamless load balancing
- Remote control and monitoring via smartphone devices
- Priority setup for heating or cooling



## RESOL MX

Performs multi-temperature distribution and solar thermal integration.

### FEATURES:

- 14 relay outputs and 12 inputs
- most versatile system controller for complex solar and heating systems in Resol product range.
- Easy combination and parameterisation of pre-programmed functions for several millions of hydraulic variants.



## HBX ZON-0550

Provides central zone control, and can be paired with HBX Thermolinx for cloud-based monitoring.

### FEATURES:

- Manage comfort for multiple zones
- Remote access via smartphone device when paired with Thermolinx
- Fan coil control
- 24V relay integration
- Air handler control with dehumidification



## CALEFFI ZONE RELAY

Provides basic zone control. Can be used with 24V and 120V relays.

### FEATURES:

- ZSR - single and multi-zone pump switching relays
- ZVR - multi-zone pump and valve switching



## HBX-0500 THERMOSTATS

Touch screen heating and cooling thermostats. Paired with ZON-0550.

### FEATURES:

- Touch screen
- Zone priority
- Humidity/dewpoint control
- Remote access via smartphone device when paired with Thermolinx
- Programmable menus
- Multiple heating and cooling modes



## HBX THERMOLINX

Adds remote app connection capability to the ZON-0550.

### FEATURES:

- Remote access monitoring and control via HBX Zone App
- Control up to 20 zones remotely to maximize comfort and energy savings
- Simple easy to use platform



## ORDERING AND DELIVERY

Once your Arctic package has been custom configured by your representative, it can be purchased using a variety of methods. Arctic packages can be affordably delivered across North America to most residential addresses.

Arctic takes great effort in ensuring your package components arrive and perform correctly. Each Arctic heat pump is individually tested before shipping, and all components are shipped well-packaged and protected.

## INSTALLATION AND SERVICE

All Arctic packages and components can be installed and serviced by local plumber or HVAC technician. In a large portion of North America, an Arctic Installer can also be hired to assist with your project.

## WARRANTY

Arctic offers a 3-year warranty on all individual components in your Arctic package. All claims handled internally by Arctic in a timely and effective manner.



## BUSINESS OPPORTUNITIES

As part of a rapidly growing industry, Arctic offers very attractive third-party partnership positions throughout North America. Contact us for more information.



# FREQUENTLY ASKED QUESTIONS

## 1. Why Choose air to water over geothermal?

- a. For the average North American, an Arctic heat pump and a standard geothermal heat pump will provide very similar average COP throughout the year. However, the equipment, installation, and maintenance costs associated with an equivalently sized geothermal system vs. Arctic are vastly higher. This results in a longer payback for geothermal.
- b. Air to water requires no excavation of property. No worrying about the specs of your aquifer. Arctic can be installed in almost any residential setting.
- c. Sound. Arctic heat pumps are not only installed outdoors, but their state-of-the-art Panasonic EVI variable speed compressors and DC fan motors are phenomenally quiet. With no starting capacitor like geothermal, owning an Arctic heat pump is a very non-invasive experience.
- d. Reliability. From our experience, the tried and tested reliability of our Arctic heat pumps has been far superior to geothermal.
- e. High loads - Arctic heat pumps are designed to be paired. It is as easy as hooking up two Arctic heat pumps to your buffer tank/s, and setting your HBX controller so the two units have 50/50 split run times. This makes them extremely convenient for large homes, or small commercial spaces. It is alot more difficult to set up a functional and reliable dual geothermal heat pump system.

## 2. Do I require an Arctic snow stand?

- a. In climates that see sub-freezing temperatures, our Arctic snow stand is recommended for proper performance of Arctic de-frost function.

## 3. What happens when the heat pump is in defrost mode?

- a. The intelligent de-frost mode on an Arctic heat pump is activated when ice build-up is detected by sensor. Condensation builds up on heat exchanger during day, freezing at night and potentially causing issues if left unchecked. The Arctic heat pump senses this build up and is programmed to operate reverse cycle for a set interval of time to warm up heat exchanger and melt ice buildup where it then drains out drain hole at bottom of heat pump.

## 4. Do I need a backup boiler?

- a. Any Arctic customer living in a climate that gets prolonged sub-freezing outdoor temperatures requires an automatic backup boiler with their Arctic heat pump. This backup boiler can take over your heating load if the Arctic heat pump cannot keep up, but more importantly if the Arctic heat pump were to go down in winter a backup boiler ensures your ability to maintain building heat at all times.

## 5. Can I use my existing hydronic boiler as a backup with your package, or a gas/propane boiler instead of electric?

- a. In most cases yes, we can adjust any Arctic Engine package to substitute our electric backup boiler for your existing boiler or a gas/propane unit. In the case of gas boilers, you would source yourself as we do not supply gas boilers. We also do not design for wood or solar thermal backup boiler systems.

**6. Instead of purchasing an LV-Z or HE-Z air handler, can I use my existing forced air furnace as fan and backup source, and purchase a standard hydronic coil for ducts?**

a. It a logical question, but Arctic engines are a low supply emitting system. Standard furnace coils work fine with 140-180F supply temp, but to produce high BTU at 115 F a high mass coil is required. If an efficient high mass coil is used with a standard forced air furnace fan, it is very likely that hydronic coil would restrict airflow to house causing multiple issues. Plus, operating a furnace for fan and backup source is difficult to setup control wise. LV-Z and HE-Z air handlers have variable speed fans, meaning the equipment owner can adjust fan speed to account for restrictive heat exchanger and perfectly tailor their forced air system performance to their liking.

**7. When you say your heat pumps heat down to -30C/-22F, what does that mean?**

a. The Arctic heat pump does not allow itself to operate in outdoor temperatures below -30C/-22F. When the outdoor temperature is just warm enough to meet operating threshold, our EVI units will still be producing just shy of half name plate BTU capacity at a COP of about 1.8. If you live in a climate that does not see -30C/-22F, and you have a manual J study performed, it is very easy for us to size an Arctic heat pump system to meet your demand loads 100% of the year.

**8. What is the hottest outdoor temperature Arctic EVI heat pumps can produce cooling in?**

a. The Arctic EVI heat pump will cease operating in cooling mode when the outdoor temperature exceeds 45C/113F.

**9. Can Arctic Engine packages hookup to conventional baseboard heaters/radiator systems?**

a. It is extremely rare this can be done effectively. Most hydronic baseboard heaters or radiators were designed/sized to heat their respective rooms/zones at a very high supply temperature. 160-180F being common. If you hook up our low supply temp heat pump to one of these systems, it is very likely your distribution system will not be able to keep up with demand load of house, thus compromising your ability to maintain comfortable air temperature.

If you can pre-determine that 120F supply temperature will provide satisfactory heating results with your radiators before purchasing Arctic Engine (you set current boiler system to run at 120F or mix temp down) it is feasible to use Arctic engine as power source. However, most customers will have to look at retrofitting Hi-Velocity or fan coils as new distribution systems into their homes. This will not only provide much better efficiency being able to heat home at much lower supply temp but will also allow for home cooling as well. Something baseboard heaters and radiators cannot do.

**10. Does my Arctic hydronic system require glycol/water mix?**

a. Typically, yes. Most Arctic customers operate their heat pumps in climates that see sub-freezing temperatures. Since hydronic lines are sent outdoors to heat pump, and your Arctic system will be fully open loop, glycol is required to prevent freezing. The percentage glycol/water mix is determined by lowest outdoor temperature possible in region. Max percentage = 40%. Some customers who were formerly using water only in floor heating might first want to explore using a heat exchanger to keep water in floor and Arctic engine fluid separate. However, a heat exchanger provides very poor results when paired with low supply temperature sources. Also, it is common practice in North America to run glycol water mixed hydronic floor systems to ensure that in worst case scenario situation hydronic system never prone to freezing and causing irreparable damage.

**11. Can I pair an Arctic Engine with a wood boiler?**

a. Not with our designs. Wood boilers produce to many variables to be feasibly paired with our Arctic engine. We suggest using standalone fireplace instead. You can opt to keep a wood boiler plumbed into your new Arctic system, but it can only be fired if Arctic system completely off.



# FREQUENTLY ASKED QUESTIONS

## 12. I heard that in floor cooling causes condensation issues?

a. Modern in floor cooling is different from radiant cooling of the past. New advanced control systems can monitor for condensation forming on the radiant cooling system, instantaneously stopping or warming up the cold fluid being sent to the hydronic manifolds. This completely eliminates the risk of condensation. However, as a by product of producing no condensation, external dehumidification methods might be required. Especially since radiant floor cooling's only limitation for achieving a desired cold air temperature is humidity level. Radiant cooling is one of our most popular cooling methods. It is affordable and efficient, and for most customers it is very effective. If you are a customer who requires very cold room temperatures, or you like to change temperatures on the fly, we might recommend looking at a direct to air cooling source.

## 13. Arctic heat pump vs. carbon heating alternatives?

a. Although electricity is a universal power source in North America, it's a relatively expensive resource compared to carbon alternatives when used for space heating. That is why the majority of North America gets their heat from direct carbon burning. We have put together an average \$/KWH rate for all major heating sources in 2020. This is a North America wide price average. Prices of energy sources vary widely per utility provider and location. The average efficiency of each heating source has been factored into these figures, and we have compared each heating source to our Arctic heat pump. Green represents savings/kwh, red represents spending/kwh.

Arctic Heat Pump \$.045/KWH		*ROUGH AVERAGES*
1. OIL \$.06/KWH	Vs. Arctic Heat Pump \$-.015/KWH	
2. Natural Gas \$.04/KWH	Vs. Arctic Heat Pump \$+.005/KWH	
3. Propane \$.074/KWH	Vs. Arctic Heat Pump \$-.029/KWH	
4. Wood \$.034/KWH	Vs. Arctic Heat Pump \$+.011/KWH	
5. Electric \$.13/KWH	Vs. Arctic Heat Pump \$-.085/KWH	

# ARCTIC HEAT PUMPS



**Thank you for your time! Contact us if you have any questions.**

835 Kapelus Dr. West St Paul, MB R4A 5A4, Canada

1-800-317-9054

[sales@arcticheatpumps.com](mailto:sales@arcticheatpumps.com)

[www.arcticheatpumps.com](http://www.arcticheatpumps.com)

